

Flow measurement with D30 sensors at working temperatures up to +350 °C optional with integrated transducer UFA capable of parameterization

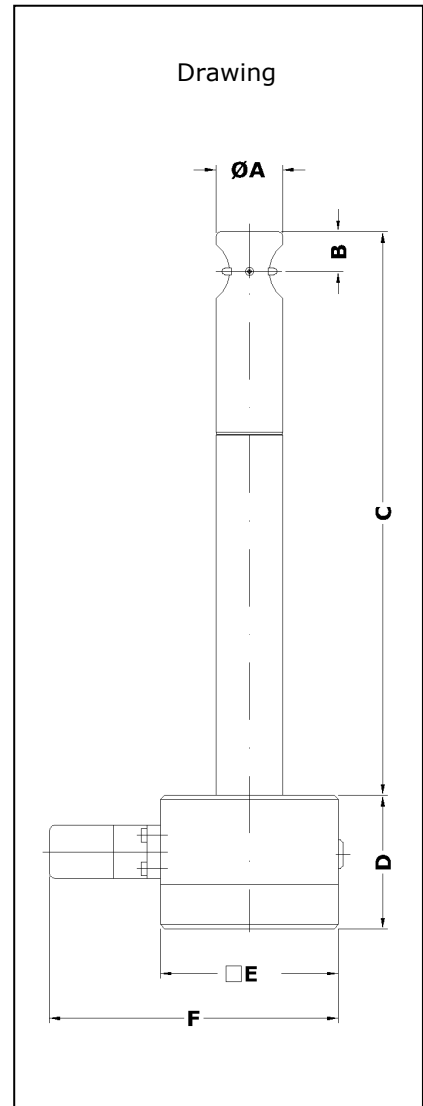
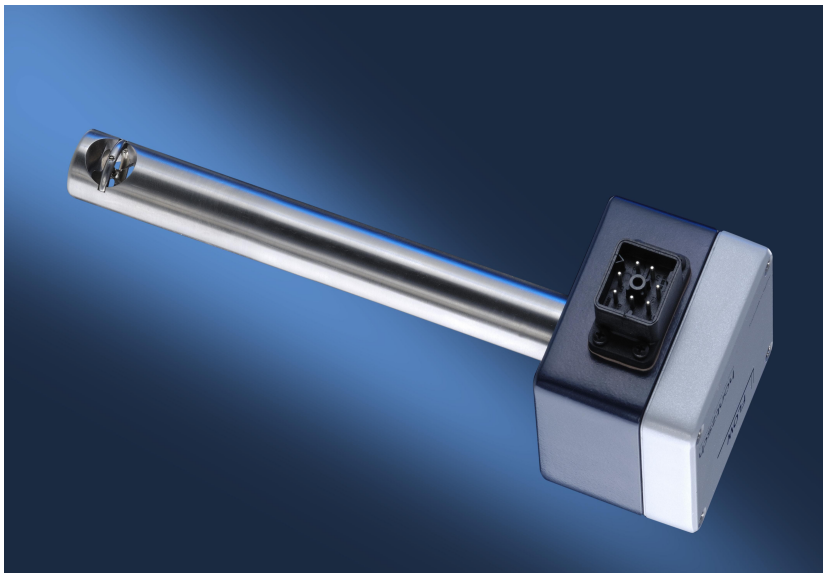

Vane wheel flow sensor D30
(see Page 3 for measurements)

Measurable variable

- actual flow velocity v [m/s] in air/gases

Measuring range

- 0.3 ... 3.0 m/s

Functional principle

- vane wheel flow sensor
- scanning the vane rotation; non-contact inductive proximity switch

Advantages

- minimum reaction time
- high time yield thanks to ultralight titanium vane wheel which is easy on the bearings
- corrosion resistant
- can be sterilized
- high working temperature and pressure range
- operates largely irrespective of density and composition of gas
- low pressure drop
- easy adjustment to process parameter

Design

- insertion probe with AS80 housing

Medium

- air, gas mixtures and clean gases

Range and examples of application

- flow measurement of air, exhaust gas, process gas, for example
- monitoring laminar flow
- monitoring flow in pharmaceutical works

Humidity in the gas

- relative gas humidity of less than 100 % does not affect the measuring uncertainty

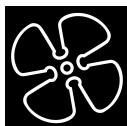

Model designation (example)							
FA	Flow	Sensor	/UFA	D30	C250	T100	Ex

Basic types

Type	Transducer/output	Article No.
Design '100 °C' / integrated UFA		
FA Flow Sensor / UFA D30 C250 T100	UFA-AS80 / 4-20 mA	HB14-a129-ufa
FA Flow Sensor / UFA D30 C350 T100	UFA-AS80 / 4-20 mA	HB14-a130-ufa
FA Flow Sensor / UFA D30 C450 T100	UFA-AS80 / 4-20 mA	HB14-a131-ufa
FA Flow Sensor / UFA D30 C550 T100	UFA-AS80 / 4-20 mA	HB14-a132-ufa
FA Flow Sensor / UFA D30 C680 T100	UFA-AS80 / 4-20 mA	HB14-a133-ufa
Design '350 °C' / integrated UFA		
FA Flow Sensor / UFA D30 C250 T350	UFA-AS80 / 4-20 mA	HB14-a109-ufa
FA Flow Sensor / UFA D30 C350 T350	UFA-AS80 / 4-20 mA	HB14-a110-ufa
FA Flow Sensor / UFA D30 C450 T350	UFA-AS80 / 4-20 mA	HB14-a111-ufa
FA Flow Sensor / UFA D30 C550 T350	UFA-AS80 / 4-20 mA	HB14-a112-ufa
FA Flow Sensor / UFA D30 C680 T350	UFA-AS80 / 4-20 mA	HB14-a113-ufa
Design '100 °C' / ext. evaluation unit		
FA Flow Sensor D30 C250 T100	ext. e-unit nec. / v/FA	HB14-a129
FA Flow Sensor D30 C350 T100	ext. e-unit nec. / v/FA	HB14-a130
FA Flow Sensor D30 C450 T100	ext. e-unit nec. / v/FA	HB14-a131
FA Flow Sensor D30 C550 T100	ext. e-unit nec. / v/FA	HB14-a132
FA Flow Sensor D30 C680 T100	ext. e-unit nec. / v/FA	HB14-a133
Design '+350 °C' / ext. eval. unit		
FA Flow Sensor D30 C250 T350	ext. e-unit nec. / v/FA	HB14-a109
FA Flow Sensor D30 C350 T350	ext. e-unit nec. / v/FA	HB14-a110
FA Flow Sensor D30 C450 T350	ext. e-unit nec. / v/FA	HB14-a111
FA Flow Sensor D30 C550 T350	ext. e-unit nec. / v/FA	HB14-a112
FA Flow Sensor D30 C680 T350	ext. e-unit nec. / v/FA	HB14-a113

(1) Transducer (see Page 2, 'Basic types')

Vane wheel flow sensor D30 optional integrated transducer UFA (see Page 3, 'Output / transducer')

(2) Sensor type / Sensor diameter

...D30... Vane wheel flow sensor D30 with sensor Ø 30 mm and shaft Ø 30 mm

(3) Sensor length measurement C (see drawing Page 1)

... C ... 250 / 350 / 450 / 550 / 680 mm

Materials in contact with the medium

Design	Material
.....	stainless steel 1.4404 / AISI 316L, titanium, ceramics Al ₂ O ₃ 99,9 %, pure graphite



Vane wheel type / Measuring range

Design	Measuring range
... md3T ...	0.3 ... 3.0 m/s (with a gas density of approx. 1.2 kg/m ³)
Measuring uncertainty	< 1.5 % of reading + 0.03 m/s
Consistency	± 0.02 m/s

(4) Permissible temperature of the medium

Design	Temperature
... 100 ...	-20 ... +100 °C (continuous)
... 350 ...	-40 ... +350 °C (continuous) -40 ... +400 °C (short-time)

ambient temperature	-40 ... +80 °C	with separate evaluation unit
	-40 ... +80 °C	with integrated transducer UFA-int
	-5 ... +50 °C	with 'LCD' option

Max. working pressure / Type of protection for sensor

up to 6 bar / 600 kPa above atmospheric
type of protection IP68

(5) Option 'Ex'

Type of protection	Art.-No.	Comment
Ex ia IIC T6 Gas-Ex: Category 2G (Zone 1)	faex1	only in connection with: <ul style="list-style-type: none"> isolation/supply unit LDX2 <u>and</u> 'non-Ex evaluation unit or compatible separate evaluation unit with Ex-output
Ex nA IIC T6 Gas-Ex: Category 3G (Zone 2) Ex tc IIIC TX Dust-Ex: Category 3D (Zone 22)	faex2	only in connection with: <ul style="list-style-type: none"> evaluation unit or flowtherm NT

Design

as Drawing (Page 1)					
measurements	A	Ø 30 mm	B	18 mm	C 250/350/450/550/680 mm
	D	60 mm	E	80 mm	F 130 mm

Connection housing AS80

measurements	80 / 80 / 60 mm (l / b / h)
connection	connector GO 070 with terminal screws
terminal connections	see Page 4
type of protection	IP65

Output / transducer (see Page 2, 'Basic types')

output 4-20 mA / integrated UFA	UFA transducer integrated in the sensor housing (see Page 4)
output sensor v/FA / sep. eval. unit necessary	Höntzsch evaluation unit with v/FA input necessary for signal evaluation
output sensor v/FA-Ex, sensor with option 'Ex' for use in Category 2G (Zone1) / sep. eval. unit necessary	Höntzsch evaluation unit with intrinsically safe v/FA-Ex signal or evaluation unit with v/FA input in conjunction with a series connected isolation/supply unit necessary for signal evaluation

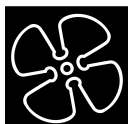

Design - Transducers UFA-int, integrated in the sensor connection housing

analog output / burden	4 ... 20 mA, burden max. 400 Ohm	
output limit value	Open Collector / max. 50 mA / max. 27 V DC	
PC interface	RS232	
	the output signals are electrically isolated from the power supply	
self-regulation	parameter settings, sensor interface; in case of error: analog output less than 3.6 mA	
connection	connector GO 070 with terminal screws	
power supply	24 V DC (20 ... 27 V DC)	
power consumption	less than 3 W	
working temp. range	-25 ... +80 °C	
housing	sensor connection housing AS80	
EMC	EN 61 000-6-2:2001	
transducer with PC software UCOM and programming adapter capable of parameterization	Parameter	Factory settings
	analog output	4...20 mA = 0...x m/s (x = customers desire)
	time constant	1 s
	limit value v	3.00 m/s
	coefficient / profile factor	1.000

Accessories (optional)

	Description	Art. No.
LCD in housing cover	2 x 16 digit, numerals 3 mm high, working temperature range -5...+50 °C	HB10-b007
calibration cert. v/FA	calibration values 0.5;0.75;1;1.5;2;3 m/s	klbneu
PC software UCOM	for configuring the UFA/int via RS232	HB10-b052
programming adapter GO 070 / RS232	for software UCOM, connection PC Sub-D 9-pin, plug to mains supply 230VAC/24VDC	HB10-b004
Interface converter USB / RS232	connection PC : USB plug type A connection unit : Sub-D 9-pin	HB10-b100



optional LCD in housing cover

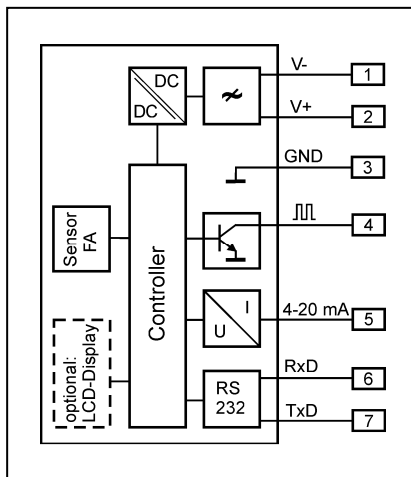

wiring diagram integrated transducer UFA

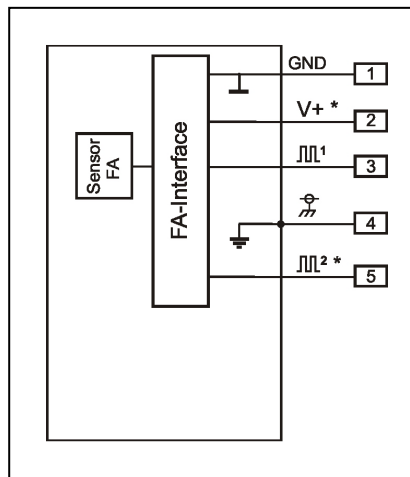

wiring diagram for external evaluation unit (* optional)

Hoentzsch GmbH
 Gottlieb-Daimler-Straße 37
 D-71334 Waiblingen (Hegnach)
 Telephone 07151/1716-0 Facsimile
 07151/5 84 02
 e-mail: info@hoentzsch.site
 Internet www.hoentzsch.site

Subject to alteration