

Vane wheel probe ZS25 for flow measurement of gases and liquids with integrated, configurable transducer UFA in Ex-d housing

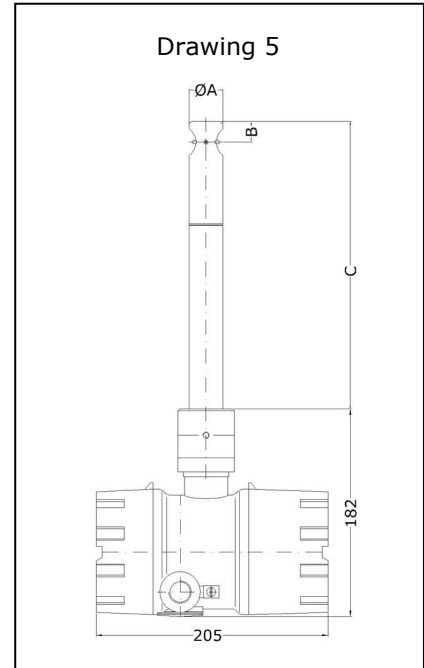

Vane wheel flow probe ZS25  
(Dimensions see Page 3)

#### Measurable variables

- actual flow velocity  $v$  [m/s] in air/gases
- (actual) flow rate [m<sup>3</sup>/h] in air/gases and water/liquids
- conversion to standard velocity/standard volume flow by entering working pressure and temperature parameters

#### Measuring range

- 0.3 ... 120 m/s air/gases
- 0.03 ... 10 m/s water/liquids

#### Functional principle

- vane wheel flow sensor
- sensing the vane rotation; non-contact by means of inductive proximity switch

#### Medium

- air, gas mixtures and clean gases
- water, liquids with viscosities of up to 200 cSt

#### Design

- insertion probe with Ex-d housing

#### Examples of application

- flow measurement e.g. of air, exhaust gas, process gas
- in processes with varying and/or unknown gas compositions
- flow monitoring in pharmaceutical installations
- monitoring inertisation processes
- measurement of flammable liquids
- measuring in non-conducting liquids such as ultra pure water, for example in the semiconductor industry

#### Advantages

- accurate measured values even in varying and/or unknown gas compositions

- compact design with optional on-site display in Ex-application
- application in category 1 (zones 0 and 20), transducer housing approved for Category 2 (zones 1 and 21)
- no external isolation/supply unit necessary

#### Humidity in the sample gas

- relative gas humidity of less than 100 % has no impact on the measurement uncertainty

#### Particles in the medium

- can cause restriction in the fatigue strength of the vane wheel set

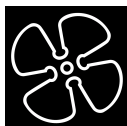

### Model designation (example)

UFA-Ex-d	-ZS25	-E	-26D	-C250		
UFA-Ex-d	-ZS25	-T	-10D	-C350	with LCD	

### Basic types

Type	Article No.
<b>'stainless steel 100 °C'</b>	
UFA-Ex-d-ZS25-E-10D-C250	HB02-a255
UFA-Ex-d-ZS25-E-10D-C350	HB02-a256
UFA-Ex-d-ZS25-E-10D-C450	HB02-a257
UFA-Ex-d-ZS25-E-10D-C550	HB02-a258
UFA-Ex-d-ZS25-E-10D-C650	HB02-a259
<b>'stainless steel 260 °C'</b>	
UFA-Ex-d-ZS25-E-26D-C250	HB02-a260
UFA-Ex-d-ZS25-E-26D-C350	HB02-a261
UFA-Ex-d-ZS25-E-26D-C450	HB02-a262
UFA-Ex-d-ZS25-E-26D-C550	HB02-a263
UFA-Ex-d-ZS25-E-26D-C650	HB02-a264
<b>'stainless steel 370 °C'</b>	
UFA-Ex-d-ZS25-E-37D-C250	HB02-a265
UFA-Ex-d-ZS25-E-37D-C350	HB02-a266
UFA-Ex-d-ZS25-E-37D-C450	HB02-a267
UFA-Ex-d-ZS25-E-37D-C550	HB02-a268
UFA-Ex-d-ZS25-E-37D-C650	HB02-a269
<b>'stainless steel 500 °C'</b>	
UFA-Ex-d-ZS25-E-50D-C250	HB02-a270
UFA-Ex-d-ZS25-E-50D-C350	HB02-a271
UFA-Ex-d-ZS25-E-50D-C450	HB02-a272
UFA-Ex-d-ZS25-E-50D-C550	HB02-a273
UFA-Ex-d-ZS25-E-50D-C650	HB02-a274
<b>'titanium 100 °C'</b>	
UFA-Ex-d-ZS25-T-10D-C250	HB02-a280
UFA-Ex-d-ZS25-T-10D-C350	HB02-a281
UFA-Ex-d-ZS25-T-10D-C450	HB02-a282
UFA-Ex-d-ZS25-T-10D-C550	HB02-a283
UFA-Ex-d-ZS25-T-10D-C650	HB02-a284
<b>'titanium 260 °C'</b>	
UFA-Ex-d-ZS25-T-26D-C250	HB02-a285
UFA-Ex-d-ZS25-T-26D-C350	HB02-a286
UFA-Ex-d-ZS25-T-26D-C450	HB02-a287
UFA-Ex-d-ZS25-T-26D-C550	HB02-a288
UFA-Ex-d-ZS25-T-26D-C650	HB02-a289

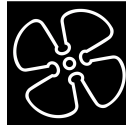

**Basic types (cont.)**

Type	Article No.
<b>'titanium 370 °C'</b>	
UFA-Ex-d-ZS25-T-37D-C250	HB02-a290
UFA-Ex-d-ZS25-T-37D-C350	HB02-a291
UFA-Ex-d-ZS25-T-37D-C450	HB02-a292
UFA-Ex-d-ZS25-T-37D-C550	HB02-a293
UFA-Ex-d-ZS25-T-37D-C650	HB02-a294

**(1) Sensor type / diameter**

Vane wheel flow sensor ZS25 with sensor Ø 25 mm and shaft Ø 25 mm

**(2) Sensor length - dimension C (see Drawing Page 1)**

250 / 350 / 450 / 550 / 650 mm

**(3) Medium**

... GF ... air / gases and water/liquids

**(4) Materials in contact with the medium**

Design	Material
... E ... stainless steel	stainless steel 1.4404 / AISI 316L, ceramics Al <sub>2</sub> O <sub>3</sub> 99.9 %, design '100 °C' and '260 °C': PTFE seal design '370 °C' and '500 °C': pure graphite seal
... T ... titanium	titanium 3.7035 (Grade 2), ceramics Al <sub>2</sub> O <sub>3</sub> 99.9 %, design '100 °C' and '260 °C': PTFE seal design '370 °C' and '500 °C': pure graphite seal

**(5) Permissible temperature of the medium**

Design	Temperature
... 100 ...	-20 ... +100 °C (constant)
... 260 ...	-40 ... +260 °C (constant), -40 ... +300 °C (short-term)
... 370 ...	-40 ... +370 °C (constant), -40 ... +400 °C (short-term)
... 500 ...	-40 ... +500 °C (constant), -40 ... +550 °C (short-term)

**Ambient** -20 ... +50 °C without 'LCD display' option

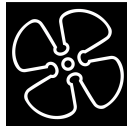

## (6) Max. working pressure / type of protection (sensor)

up to 10 bar / 1 MPa kPa overpressure  
greater working pressure on request  
type of protection IP68

## (7) Ex-protection

for gas : Ⓜ II 1/2 G Ex ia/d e [ia] IIC T6 Ga/Gb and  
for dust : Ⓜ II 1/2 D Ex ia/tb IIIC TX Da/Db  
sensor for application in Category 1 (Ex-Zone 0 or 20),  
transducer housing for application in Category 2 (Ex-Zone 1 or 21)

## (8) Design

as in Drawing 5 (see Page 1)

dimensions	A	Ø 25 mm	B	13.9 mm	C	250/350/450/550/650 mm
------------	---	---------	---	---------	---	------------------------

## Measuring range / vane wheel type

Measuring range air/gases*	Measuring range water/liquids**	Vane wheel type			Article No.
<b>with 'stainless steel' probe</b>					
0.4 ... 20 m/s	0.04 ... 7.5 m/s	mn	20	E	v_mn20GFE
0.5 ... 40 m/s	0.05 ... 10 m/s	mn	40	E	v_mn40GFE
1.0 ... 80 m/s	0.08 ... 10 m/s	mn	80	E	v_mn80GFE
1.4 ... 120 m/s	0.10 ... 10 m/s	mn	120	E	v_mn120GFE
<b>with 'titanium' probe</b>					
0.3 ... 20 m/s	0.03 ... 7.5 m/s	mn	20	T	v_mn20GFT
0.4 ... 40 m/s	0.04 ... 10 m/s	mn	40	T	v_mn40GFT
0.8 ... 80 m/s	0.06 ... 10 m/s	mn	80	T	v_mn80GFT
1.2 ... 120 m/s	0.08 ... 10 m/s	mn	120	T	v_mn120GFT

Measurement uncertainty	for air/gases and water	: < 1.5 % of measured value + 0.5 % of terminal value
-------------------------	-------------------------	---

Repeatability	for air/gases and water	: ±(0.05 % of terminal value + 0.02 m/s)
---------------	-------------------------	--

\* with an air/gas density of approx. 1.2 kg/m<sup>3</sup>

\*\* the specified measuring range for application in liquids is usable provided that cavitation does not arise around the vane wheel.

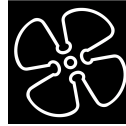

### Ex-d transducer housing

Dimensions	outside diameter/length/height: approx. 110/205/182 mm
Material	die-cast aluminium max. 0.5 % Mg, coated housing
Type of protection	IP68, IEC 529 and EN 60 529
Connection	bush for shielded cables with outside diameter 5 ... 9 mm, contacting of the overall shielding on the earth terminal in the housing; connection via screw-type terminals Ex-e for wires with cross-section 0.14 – 1.5 mm <sup>2</sup>
Alignment to the sensor	connection housing rotatable by approx. 350 ° and lockable
Set up	dual chamber system, consisting of 1) electronics in Ex-d protection (pressure-resistant casing) and 2) connection area in Ex-e protection (increased safety) with terminal block and bush

### Electromagnetic Compatibility (EMC)

according to EN 61 000-6-2 / IEC77

### Mounting attitude

any

### Transducer UFA, integrated in the connection housing

Analog output flow	4 ... 20 mA working resistance max. 500 Ohm, with HART <sup>®</sup> modem adapter: resistance min. 250 Ohm, max. 500 Ohm
Output limit value or quantity pulse	potential-free relay contact (normally open contact), max. 300 mA / 27 VDC
Communication port	HART <sup>®</sup> , via modem adapter for PC connection and PC software UCOM (see Accessories)
Self-monitoring	output signals are electrically isolated from the power supply parameter settings, sensor interface; in the case of error: analog output less than 3.6 mA
Power supply	24 V DC (20 ... 27 V DC)
Power consumption	less than 5 W
Setting parameter (selection depending on parameter set)	analog output, time constant, profile factor, tube inside diameter, limit value or quantity pulse (quality rating adjustable), switch-over actual/standard flow with setting parameters 'working pressure' and 'working temperature'

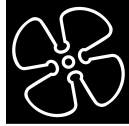

<b>Accessories (optional)</b>		
	<b>Description</b>	<b>Article No.</b>
LCD display	1st line: 'instantaneous value': flow rate or flow velocity 2nd line: 'counter' or 'error code'; 2 x 16-digit, character height 5.5 mm, working temperature range -20 ... +50 °C display rotatable in 90 °-stages on removing the window of the Ex-d housing	HB10-b520
Calibration certificate v/FA	6 standard calibration values, (see Data Sheet U183)	klbneu
HART® modem adapter	for changing the setting parameter, for PC-USB connection	HB10-b101
PC software UCOM	for configuring the transducer via RS232	HB10-b052



Ex-d transducer housing with optional LCD display

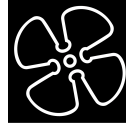

**Accessories (cont.)**

	Description	Article No.
Direction indicator RZ25	for recognition of the direction of flow and insertion depth, adjustable, for probes and probe extensions with Ø 25 mm	HB99-b953
Probe guide piece SFB25 - DN50PN16 for 550 °C as in <b>Drawing 1</b>	for any repeated positioning with marginal excess pressure (max. 2 bar/ 200 kPa) / low pressure, working temperature range - 40 ... +550 °C, through hole 25 mm, for connection to flange nipples or ball valves with flange, probe attachment with clamping bush, materials: stainless steel, graphite flange DN50 PN16 in conformity with DIN, installation length L 70 mm	HB04-b110
Probe guide piece SFK25 - G2" with clamping yoke as in <b>Drawing 2</b>	for any repeated positioning even with higher excess pressure (max. 10 bar/1 MPa) / low pressure, through hole 25 mm, for connection to threaded socket or ball valve with inside thread G 2", working temperature range -20 ... +240 °C, installation length 100 mm, materials: stainless steel, VITON®-lip seal, incl. hook spanner and hexagon screwdriver	HB04-b210
Probe guide piece SFB25 - G 1 1/4" with bushing as in <b>Drawing 5</b>	for any repeated positioning with marginal excess pressure (max. 2 bar/ 200 kPa) / low pressure, through hole 25 mm, for connection to threaded socket or ball valve with inside thread G 1 1/4", working temperature range -20 ... +240 °C, installation length 54 mm, materials: stainless steel, VITON®, PTFE clamping bush	HB04-b510

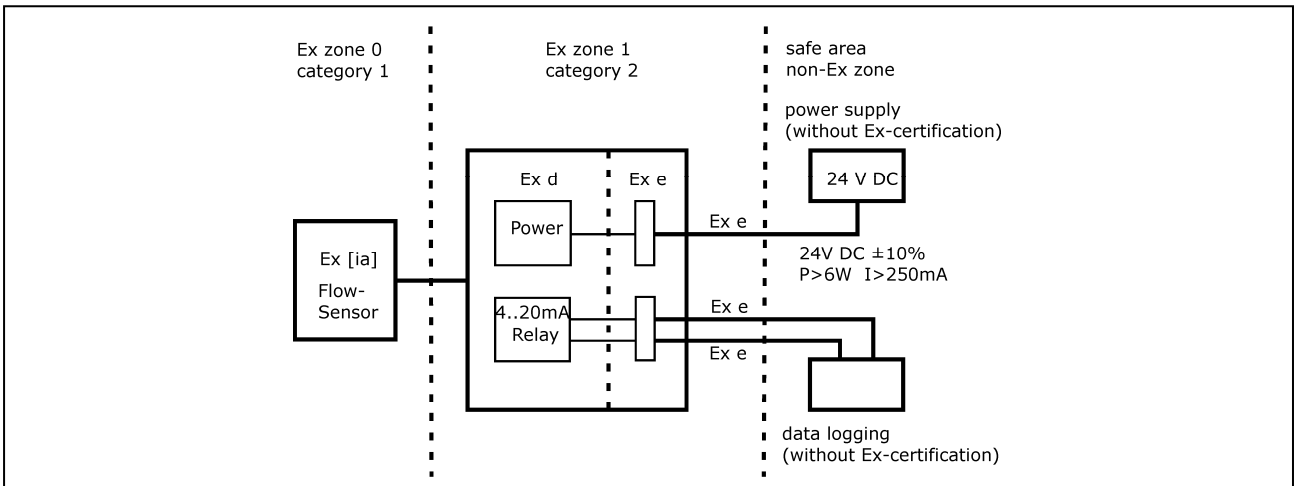
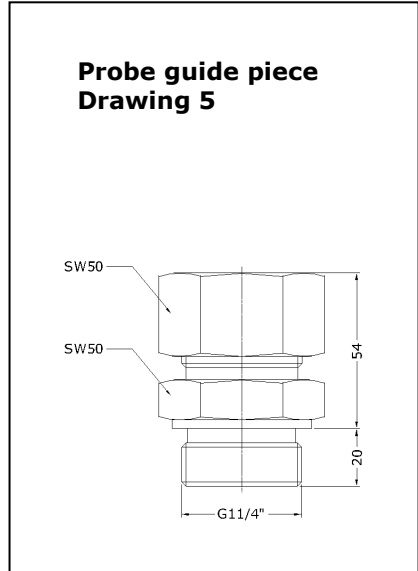
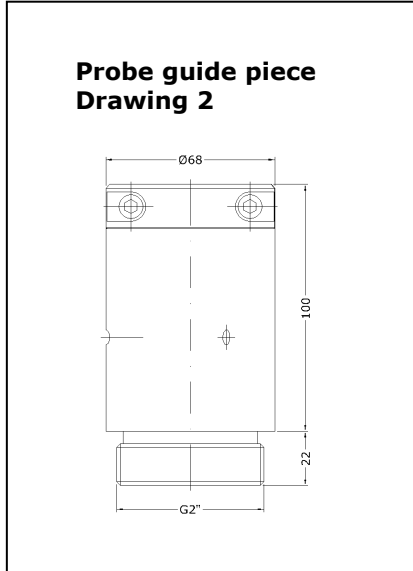
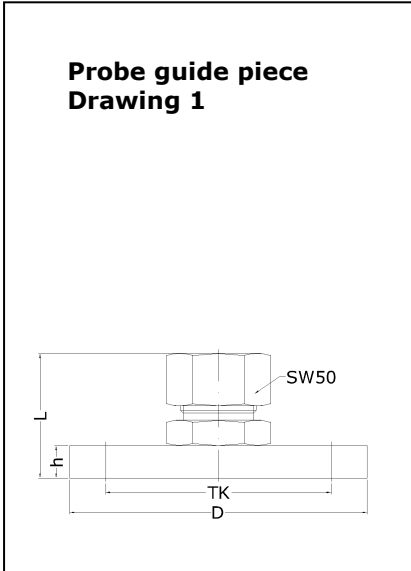
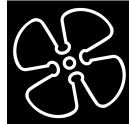

Diagram of Ex-Zones